

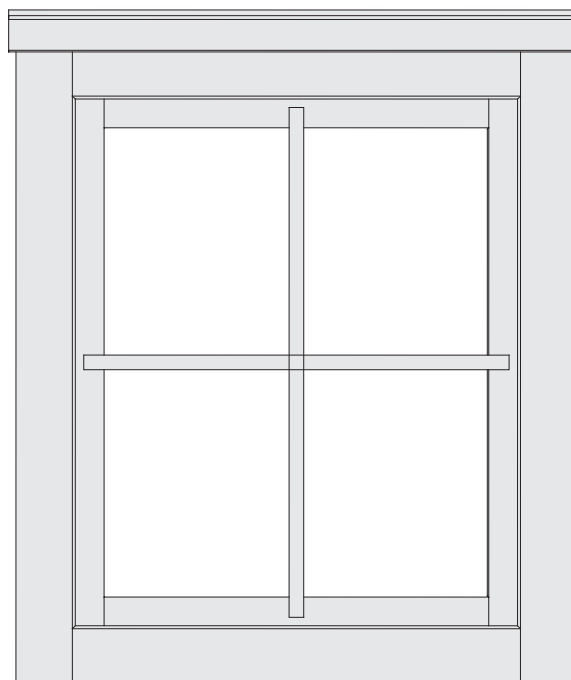



55331 83482





-  **Aufbauanleitung**
-  **Building Instructions**
-  **notice de montage**
-  **montagehandleiding**
-  **Montagevejledning**
-  **Instrucciones de construcción**
-  **Istruzioni per il montaggio**
-  **Montážní návod**
-  **Navodila za sestavljanje**

 Vergleichen Sie zuerst die Material-liste mit Ihrem Paketinhalt! Bitte haben Sie Verständnis, dass Beanstandungen nur im nicht aufgebauten Zustand bearbeitet werden können!

 Vergelijk eerst de lijst van materialen met de inhoud van uw pakket! Reclamaties kunnen alleen in behandeling worden genomen zolang de onderdelen nog niet zijn gemonteerd!

 Confrontate questa distinta materiali prima con il contenuto del pacchetto! Vi preghiamo di comprendere che eventuali reclami possono essere accolti solo prima del montaggio!

 First compare the list of materials with your package contents! Please understand that complaints can be processed in the non-built status only!

 Start med at kontrollere materialelisten med indholdet af den leverede pakke! Vi gør venligst opmærksom på at reklamationer kun kan behandles for materialer som ikke er blevet bearbejdet!

 Nejprve překontrolujte obsah balení podle materiálového listu! Mějte pochopení pro to, že případnou reklamaci se můžeme zabývat pouze tehdy, když díly nebudou smontované! Za pomoci tohoto seznamu můžete jednotlivé díly přiřadit k montážnímu návodu.

 Commencez par comparer la liste du matériel avec le contenu de votre paquet! Sachez que nous traitons uniquement les réclamations concernant le matériel à l'état non monté!

 En primer lugar, compare la lista de material con el contenido del paquete. Rogamos entienda que las reclamaciones sólo pueden ser tramitadas antes de montar el objeto!

 Najprej primerajte seznam materialov z vsebino vašega paketa! Upoštevajte, da lahko pritožbe obravnavamo le v nesestavljenem stanju!

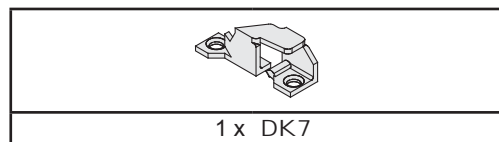
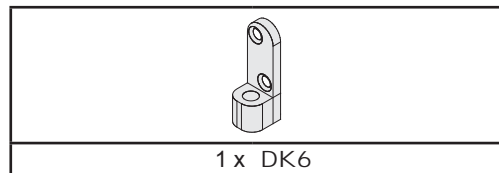
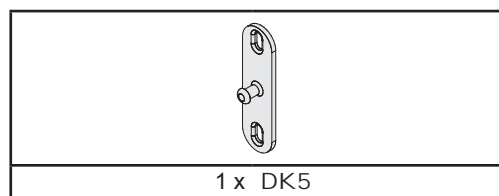
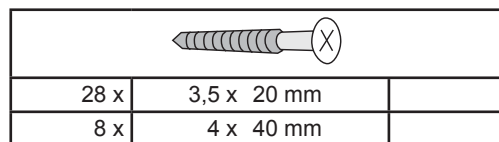
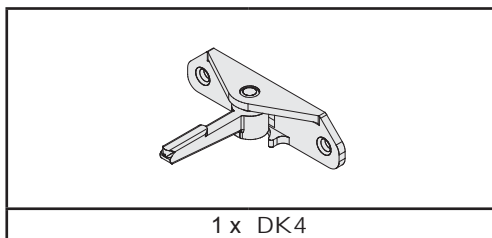
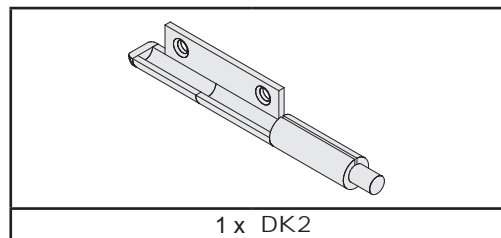
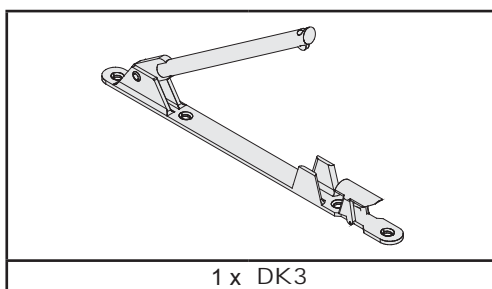
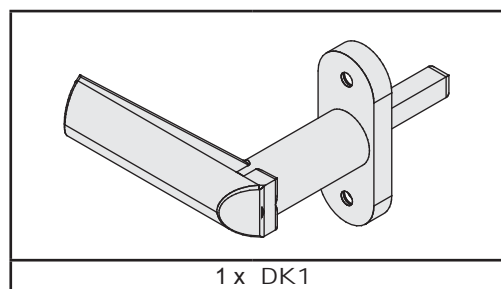
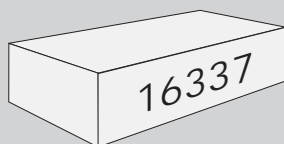
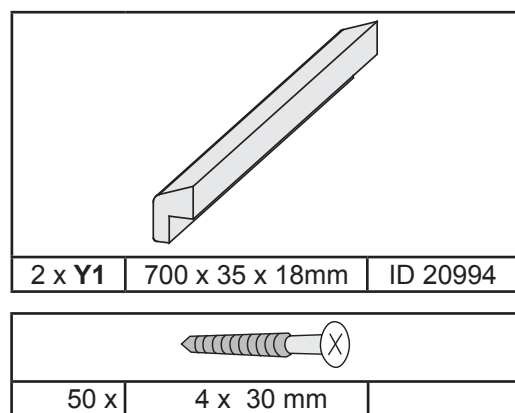
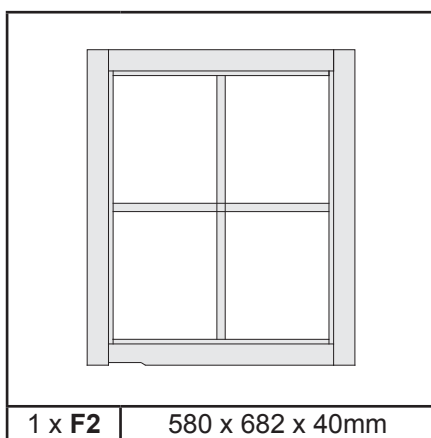
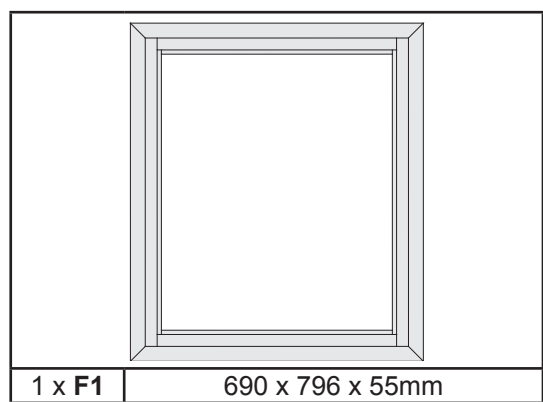
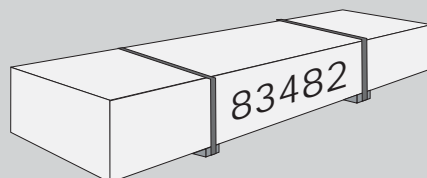
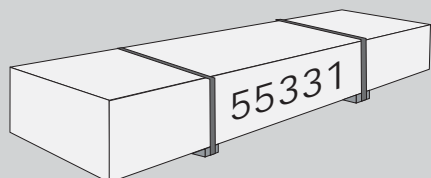

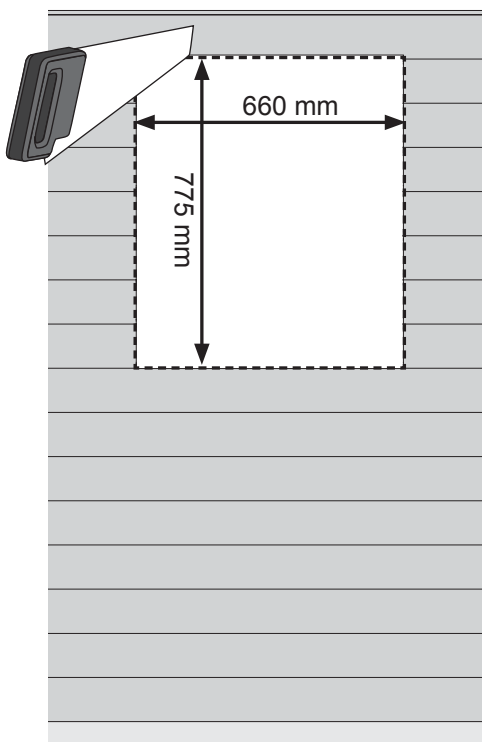

-  Ausschnitt Fenster
-  Cutout window
-  Fenêtre de découpe
-  Uitgesneden venster
-  Udskæringsvindue
-  Ventana de recorte
-  Finestra di ritaglio
-  Okno výřezu
-  Izrez za okno

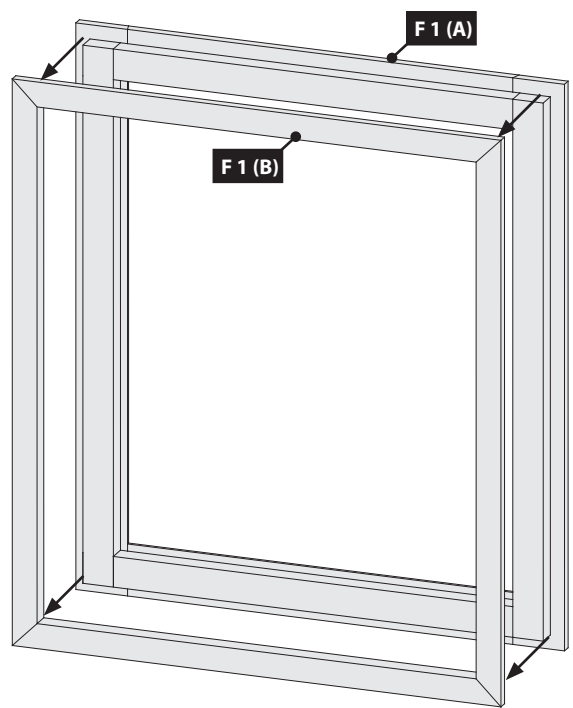
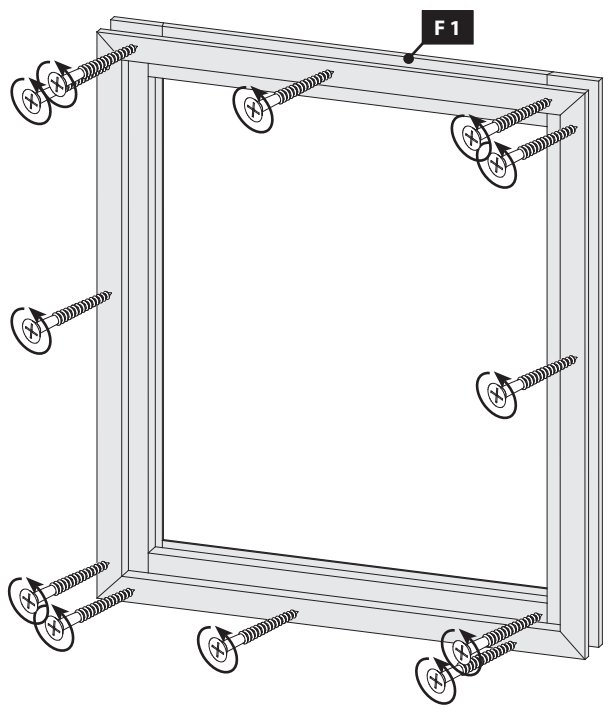

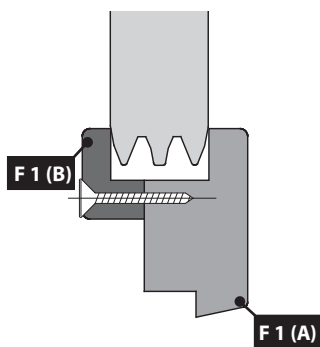
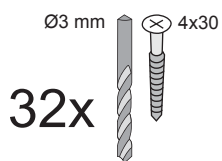

-  außen
-  outside
-  à l'extérieur
-  udenfor
-  buiten
-  fuera
-  al di fuori
-  vně
-  zunaj

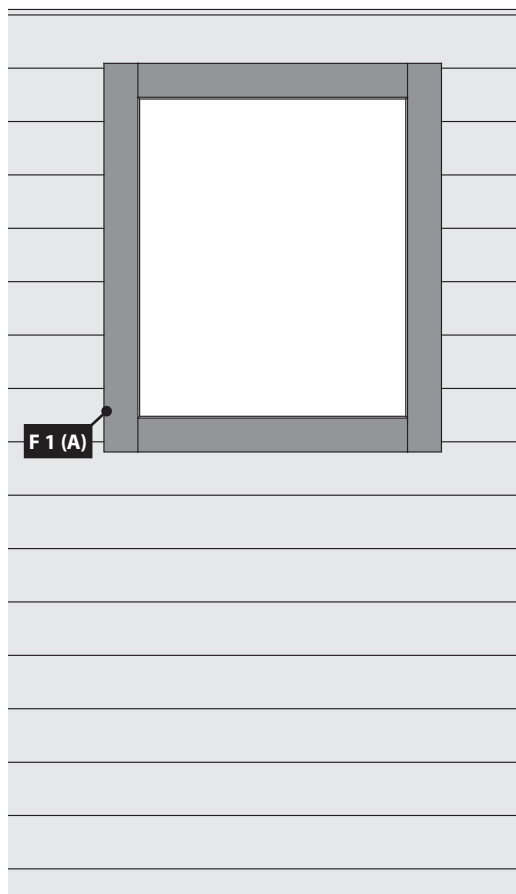

-  innen
-  Inside
-  à l'intérieur
-  inde på
-  binnen
-  dentro
-  dentro
-  uvnitř
-  znotraj

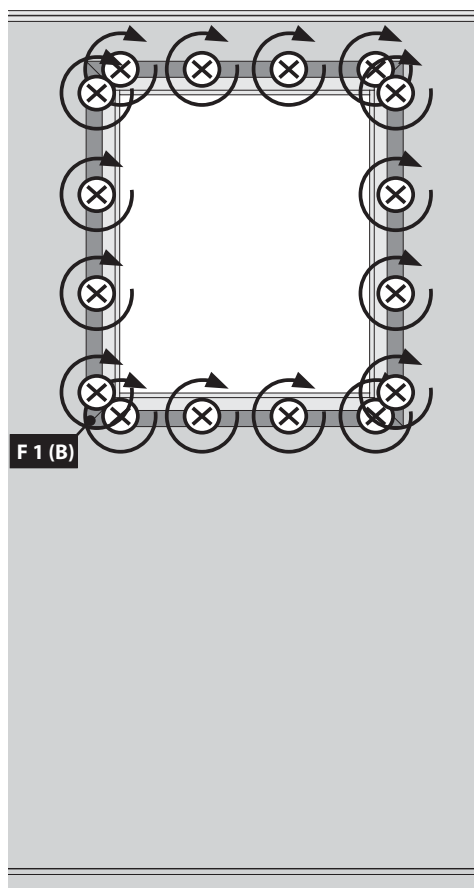

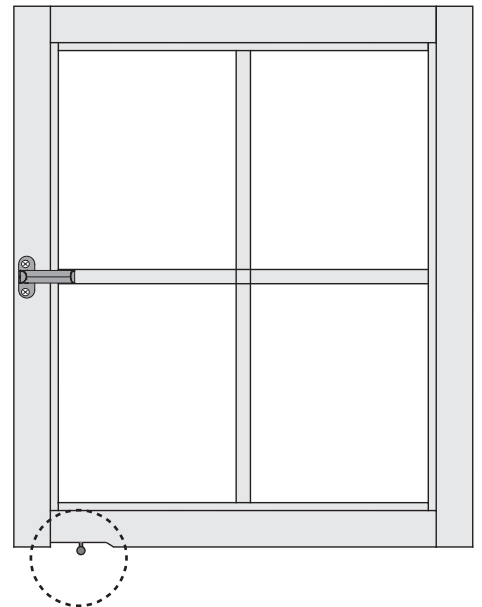
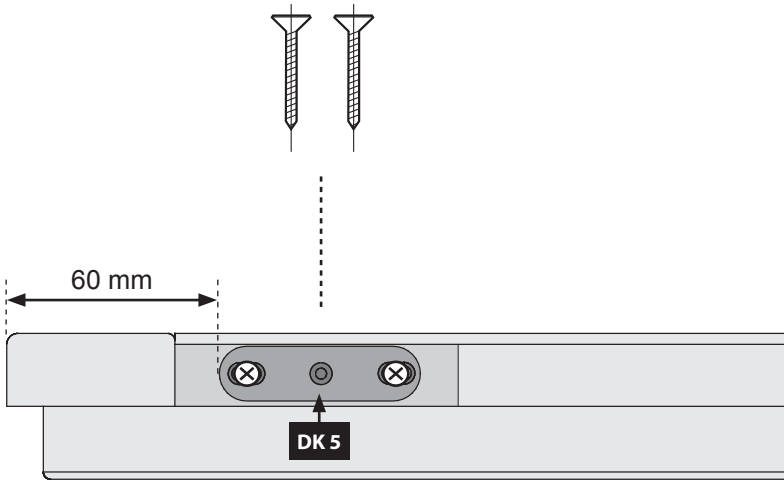
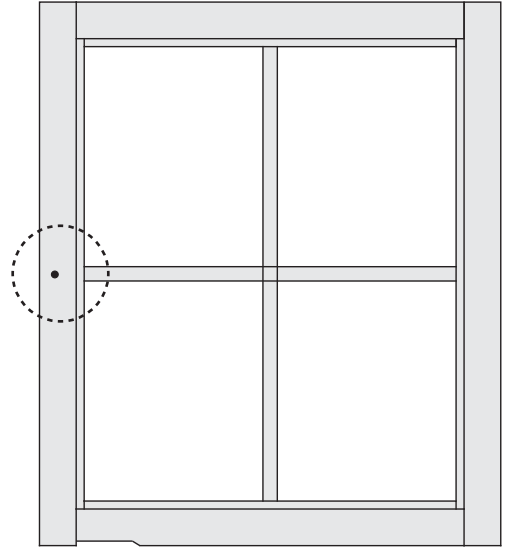
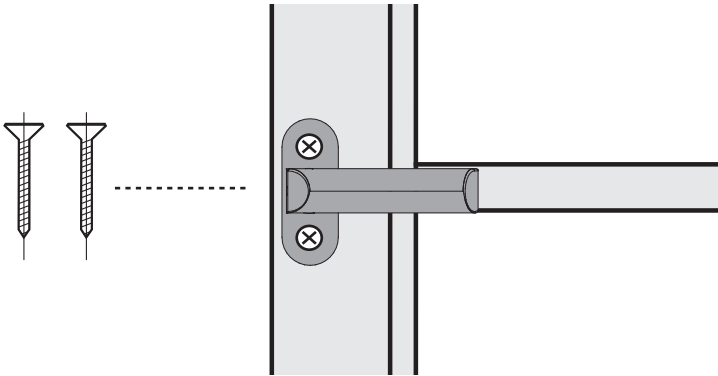
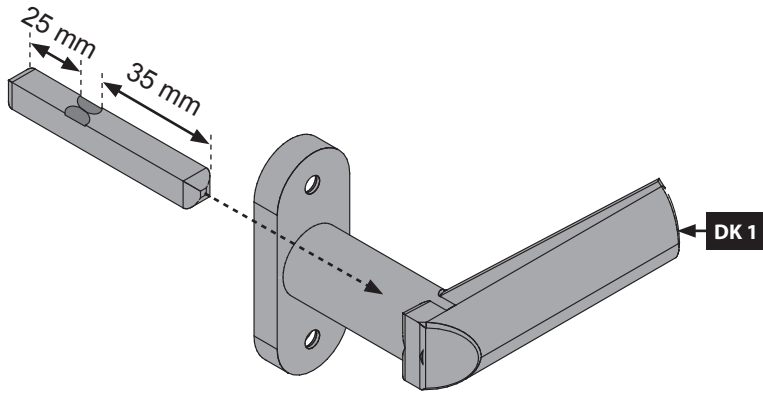

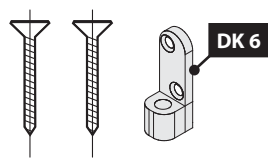
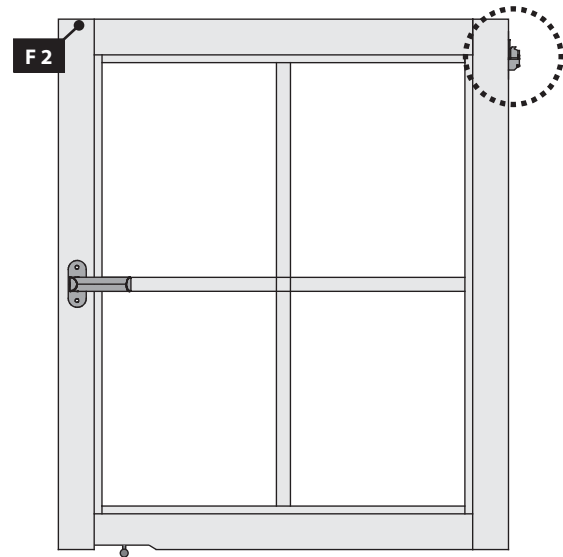
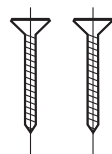
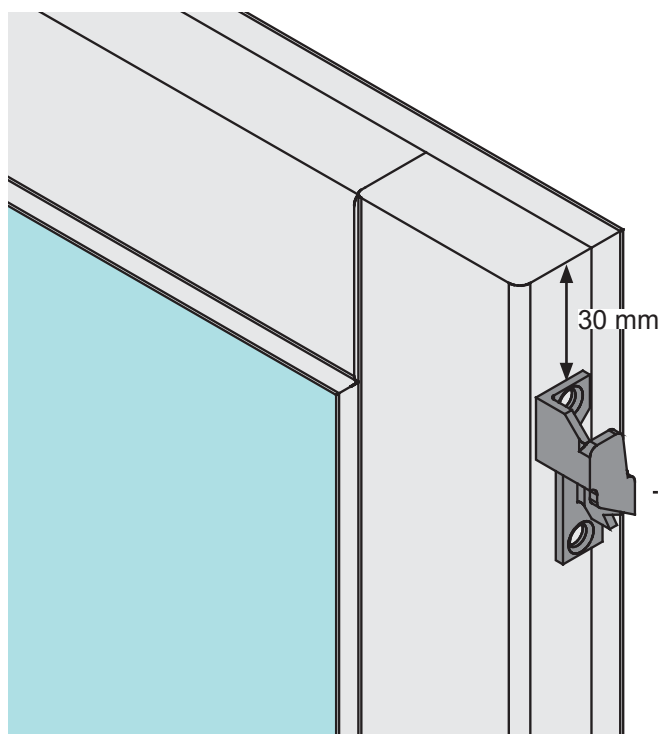
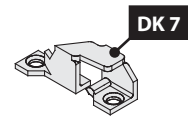

- Bündig!
- Flush!
- Affleurement!
- Gelijk!
- I flugt!
- Aras!
- Combacia!
- Stejný!
- Splakovanje!

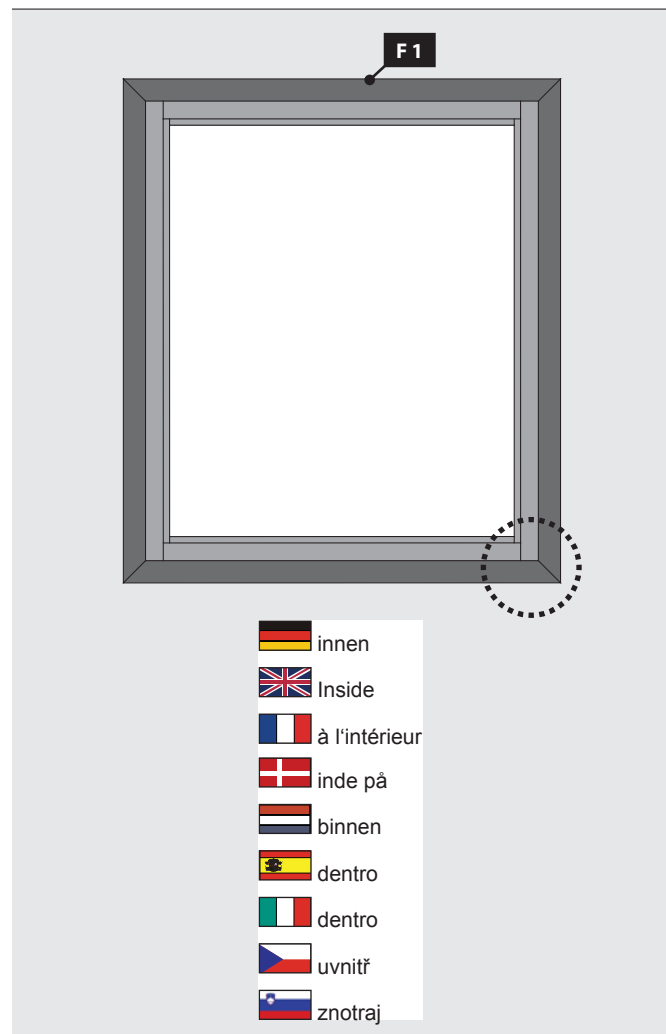
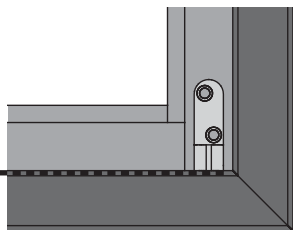



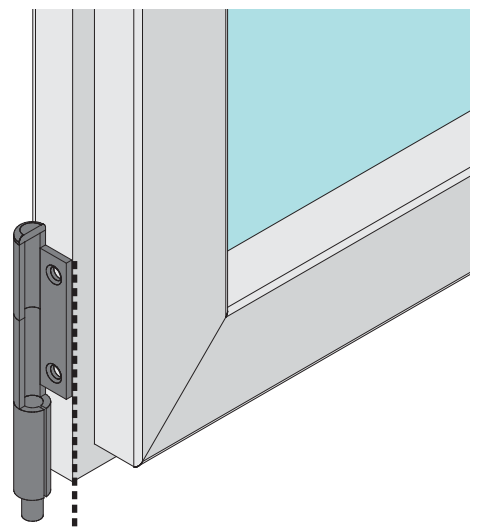
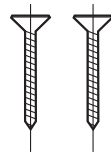
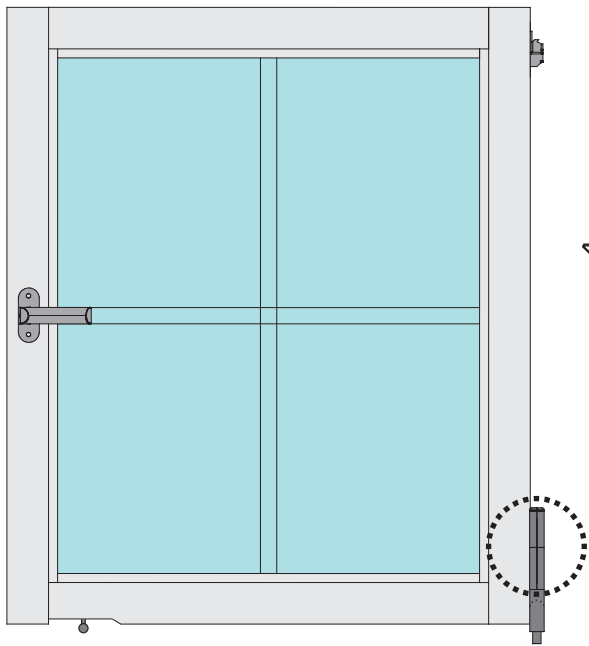
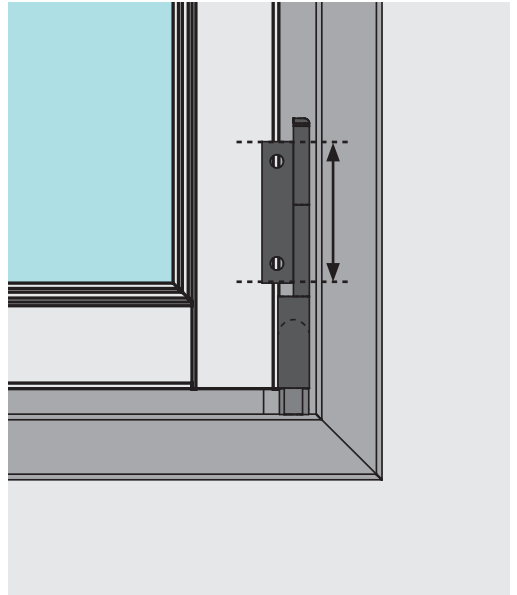
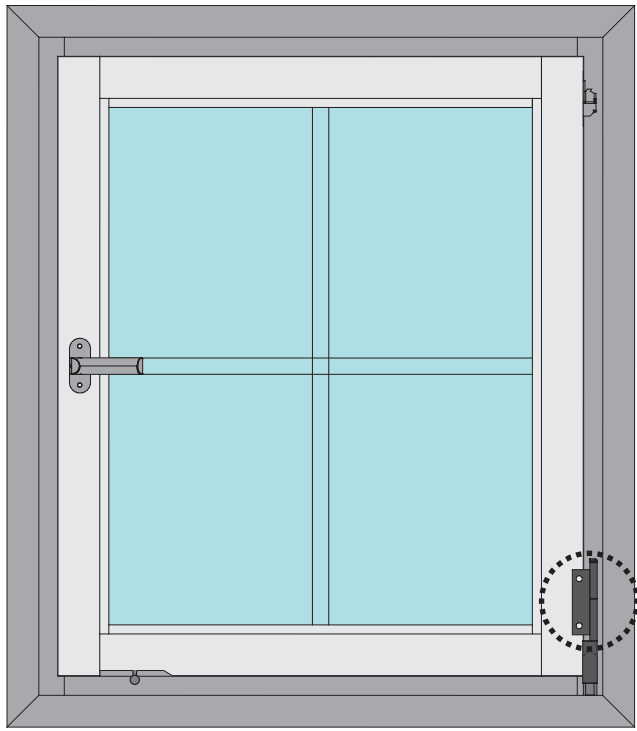
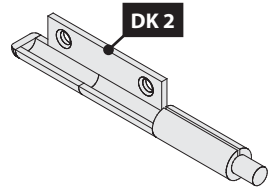



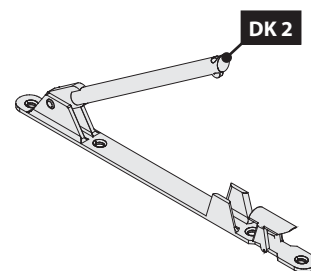
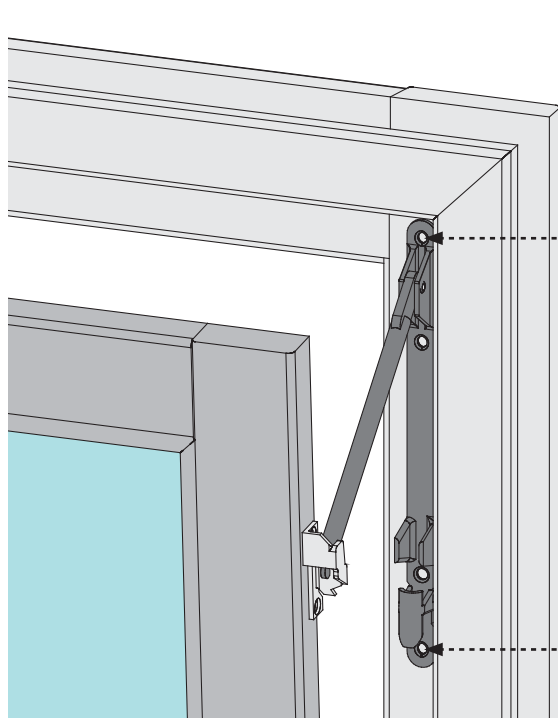
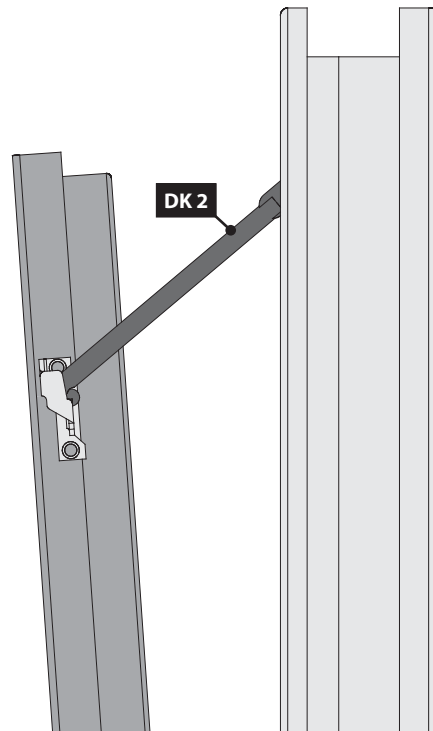
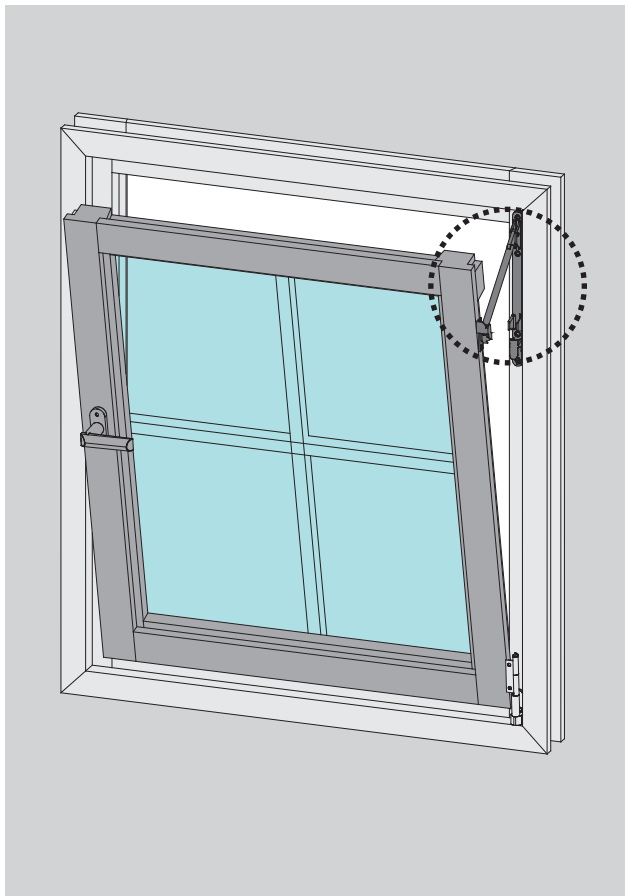

- innen
- Inside
- à l'intérieur
- inde på
- binnen
- dentro
- dentro
- uvnitř
- znotraj



-  Bündig!
-  Flush!
-  Affleurement!
-  Gelijk!
-  I flugt!
-  Aras!
-  Combacia!
-  Stejný!
-  Splakovanie!





-  Führen Sie F3 durch F4 hindurch + Festschrauben
-  Mettez le F3 per F4 + Visser
-  Put F3 through F4 + Screw on
-  Gezette F3 door F4 + Schroef
-  Pase el F3 con F4 + Tornillo encendido
-  Faccia passare il F3 con F4 + Vite sopra
-  Run F3 by F4 + přes utahování
-  Prehod F3 skozi F4 + zategnite vijak

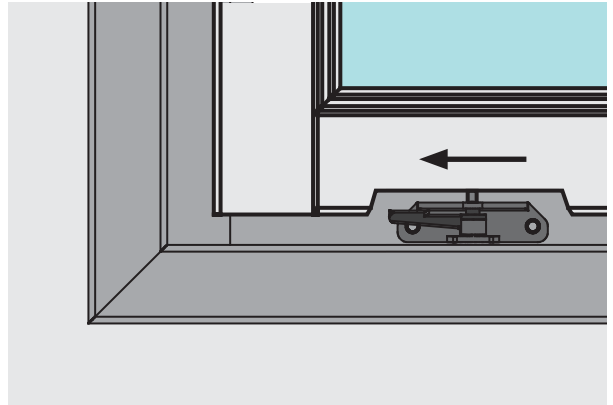
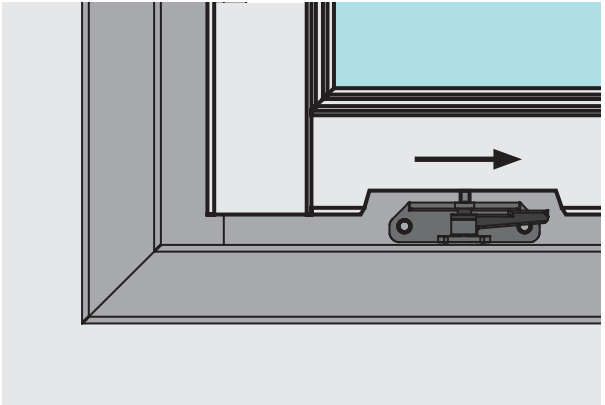
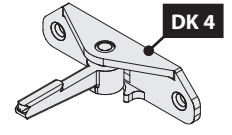
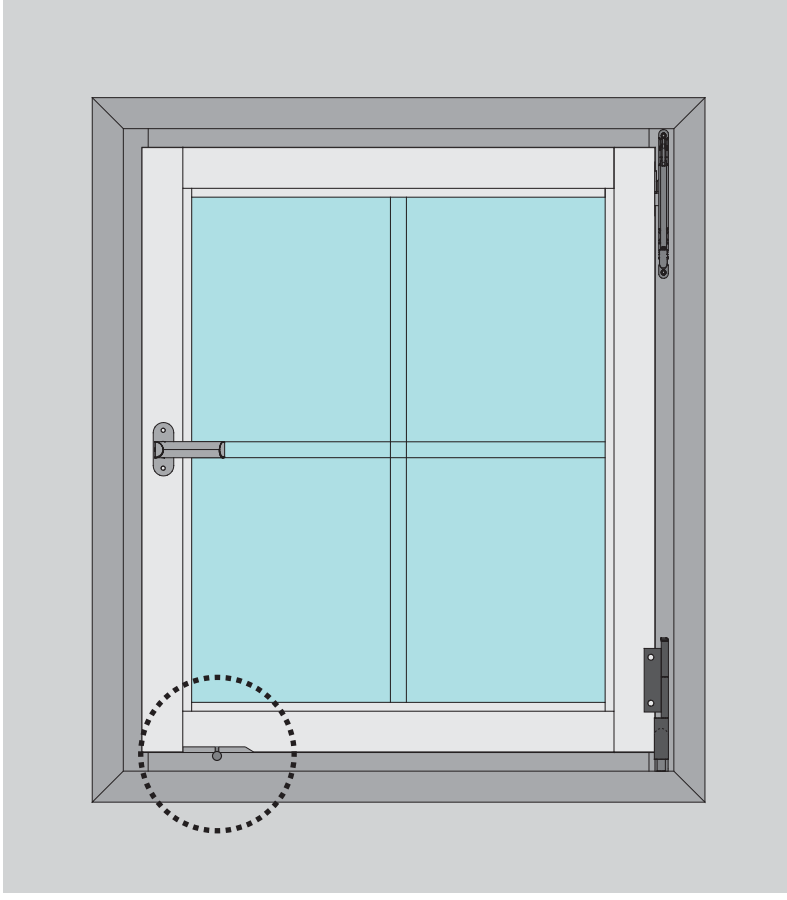

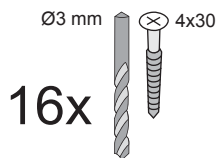







 Die Hütchenprofile dürfen nur mit dem Fenster und nicht mit dem Haus verschraubt werden!

 De afdekprofielen mogen uitsluitend op het raam, niet op het huisje worden vastgeschroefd!

 Les profils de panne sont à visser à la fenêtre, non à la maison!

 Screw the capping profiles onto the window only, not onto the cabin!

 Los perfiles de sombrerete sólo se pueden atornillar a la ventana, no a la caseta!

 I cappellotti possono essere avvitati solo alla finestra, non alla casa!

 Pokrivne profile je dovoljeno privijačiti le na okno, ne pa tudi na hišo!

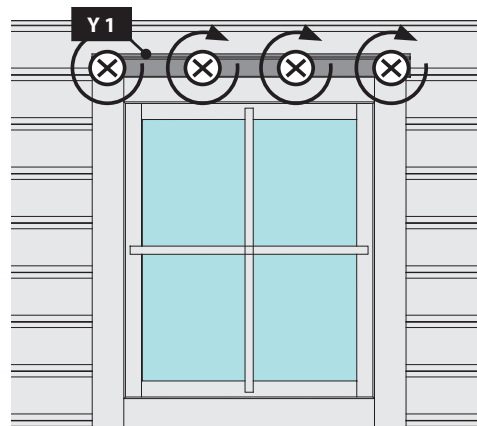

-  außen
-  outside
-  à l'extérieur
-  udenfor
-  buiten
-  fuera
-  al di fuori
-  vně
-  zunaj

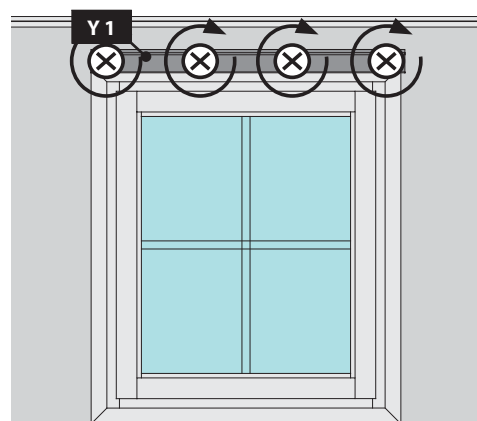

-  innen
-  Inside
-  à l'intérieur
-  inde på
-  binnen
-  dentro
-  dentro
-  uvnitř
-  znotraj